

DEVELOPMENT OF A MODERN PNEUMATIC DRYER AND PROSPECTS FOR ITS
SOLAR-TYPE WORKING PRINCIPLE

K.Qosimov

AndMBI DSc, Professor

B.Bekkulov

AndMBI PhD, Associate-prof.

U.Qayumov

Researcher Andijan machine-building institute

Annotation: *The article describes current modern and resource-efficient experimental and theoretical research, as well as analysis of the use of pneumatic structures in rural areas and other sectors of the national economy, information about the principle of converting solar radiation into thermal energy.*

Key words: *real-life drying, thermal energy, double-layer pneumatic structure, electric heater, analysis, pneumatic structures, rural areas, sectors of the economy, and etc.*

The experimental and theoretical studies carried out, as well as the analysis of the use of pneumatic structures in rural areas and other areas of the national economy, allow us to proceed to the task of substantiating, developing and manufacturing a real-life drying plant operating on the principle of converting solar radiation into thermal energy. At the same time, the dryer must function for its intended purpose and be used as an overlapping ceiling in bad weather [1, 2, 3, 4, 5].

Taking into account these requirements, we have proposed a pneumatic two-layer structure with extended functionality, shown in Fig. 1 and 2.

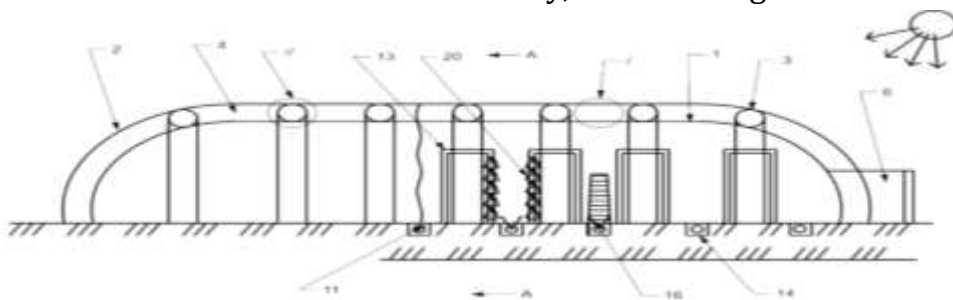

Fig.1. Double-layer pneumatic structure as a solar-radiation drying plant for drying grapes

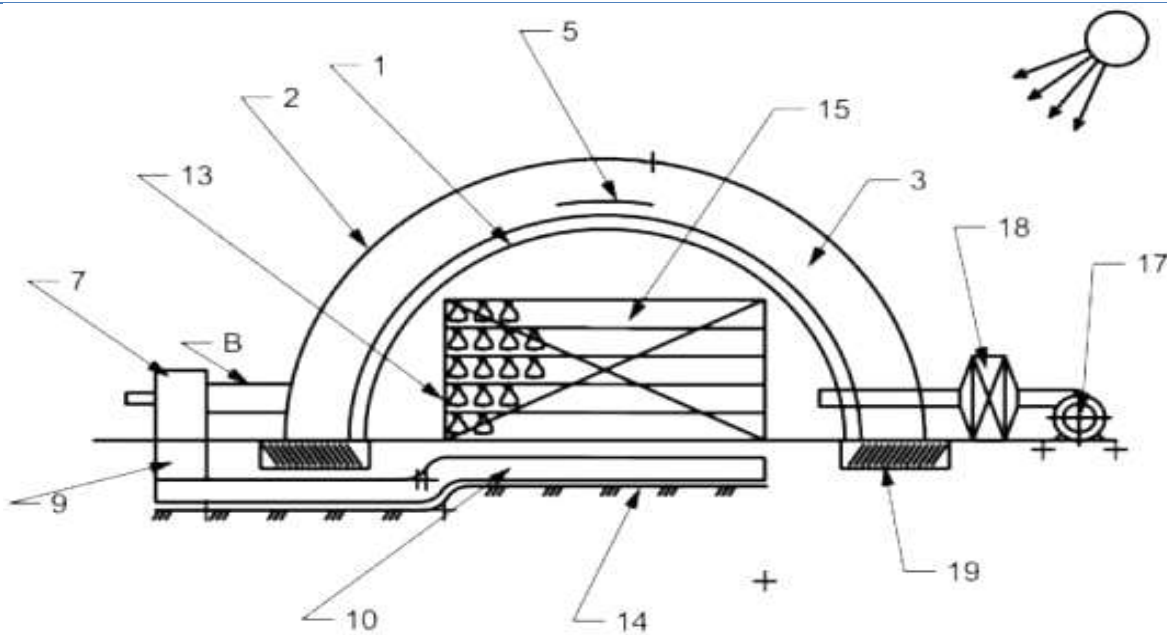

Fig. 2. Cross section of pneumatic dryer

The proposed air-supported drying plant contains an inner main shell 1 and an outer translucent shell 2, between which pneumatic arches 3 are placed, forming an intershell space 4.

The inner shell is made of reinforced dacron with a blackened neoprene coating, with solar radiation absorption capacity $n=0.52-0.6$, and the outer shell is made of chlorosulfonated polyethylene (Hypolon) [6, 7, 8, 9].

On the roof of the inner shell 1 there are at least two flexible valves 5, two air passages from the subshell space to the intershell space. From the end part of the air-supported structure there is a sealed lock 6 for the entrance of service personnel and carts with the product to be dried (not shown in the figure). On the side of the structure is a fan 7; the suction pipe 8 which is connected to the intershell space 4; and the discharge pipe 9 communicates with the air distribution manifold 10, the sleeves 11 of which are placed in the form of a comb, while drainage holes 12 are made on them, located at an angle of $90-120^\circ$ relative to each other and directed towards the drying racks 13. In order to avoid damage to the sleeves, they are placed in concrete trays 14. For the convenience of hanging bunches of grapes on hanger 15, a mobile household ladder 16 is provided. In case of operation of the drying plant at night and in rainy weather (late autumn), the structure is equipped with an additional fan 17 and an electric heater 18. Pneumatic air-supported dryer is mounted on strip foundation 19 [10, 11, 12, 13, 14].

Before starting the operation of the drying plant, a pneumatic structure is mounted. To do this, the inner main shell 1, the pneumatic arches 3 and the outer shell 2 are fixed on the prepared strip foundation 19 (they can be made together into one assembly unit at the Angren Resine-technique plant and delivered to the assembly site).

After installation, the fan 17 and the electric heater 18 are turned on and warm air is supplied under the inner shell 1, which softens under the influence of air, folds

and acquires a working semi-cylindrical shape. Upon reaching the calculated overpressure under it, the air flows through the flexible valve 5 into the inter-shell space 4 and brings the outer shell 2 into working position. working position.

Then a hermetic gateway 6 is installed and drying racks 13, a mobile ladder 16 and sleeves 11 are brought inside the structure through it. After their pre-assembly and installation, the suction pipe 8 of the fan 7 is connected to the inter-shell space 4, and the discharge pipe 9 is connected to the air distribution manifold 10.

Air dryer works as follows. Commodity drying grapes of *kishmish* varieties, for example, "Sogdiana", "Kara Botir", "Zarafshan", etc. are brought through the gateway 6 inside the pneumatic structure. Here, on non-layout tables, individual brushes are combined into larger brushes 20 and hung on hangers 15 located on both sides of the drying racks 13. The air supplied by the fan 17 is heated in the electric heater 18 and enters the subshell space and, rising up, passes through the flexible valve 5 into the inter-shell space 4. The fan 7 draws in warm air and, through the discharge pipe 9 and the air distribution manifold 10, delivers it to individual sleeves 11, through the holes 12 of which the hanging brushes 20 of the wine are blown with air. In a stream of warm air, the grapes are dried by analogy with the "*soyaki*" method [15, 16, 17, 18].

In sunny clear weather, the dryer can work with the electric heater 18 turned off.

At the same time, the Sun's rays with an intensity of $q \approx 900-1200 \text{ W} / \text{m}^2$ translucent shell 2 and, in turn, heats the air in the inter-shell space 4. In good sunny weather, the air warms up to a temperature of $55-60^\circ \text{C}$, which allows the drying process to be carried out with active ventilation.

Thus, for an electro mental drying plant with the dimensions of a pneumatic structure of $18 \times 6 \text{ m}$, the surface of the heat-absorbing roof is about $F = 3200 \text{ m}^2$. Taking on average for the city of Tashkent the intensity of solar radiation $q = 940 \text{ W}/\text{m}^2$ and the duration of insolation 8 hours, it is possible to obtain more than 2400 kW of energy, which naturally gives significant savings [19, 20, 21].

The only requirement for the operation of such drying plants is the installation of the structure in the east-west direction.

Pneumatic construction-dryer is quickly erected, transportable and can be operated in any bad weather [22, 23, 24, 25, 26].

LITERATURE:

108. Беккулов Б. Р., Атабаев К., Рахмонкулов Т. Б. ОПРЕДЕЛЕНИЕ КОЛИЧЕСТВА ШАЛЫ В СУШИЛЬНОМ БАРАБАНЕ //Бюллетень науки и практики. – 2022. – Т. 8. – №. 7. – С. 377-381.

109. Рузиев А. А. ЦЕНТРОБЕЖНОЕ СОРТИРОВАНИЕ СЕМЯН СЕЛЬСКОХОЗЯЙСТВЕННЫХ КУЛЬТУР ПО ПЛОТНОСТИ //Universum: технические науки. – 2021. – №. 12-3 (93). – С. 82-86.

110. Атабаев К., Мусабаев Б. М. ЗАДАЧА О РАСПРОСТРАНЕНИИ ВОЛН В БЛИЗИ РАСШИРЯЮЩЕЙСЯ ПОЛОСТИ ПРИ КАМУФЛЕТНОМ ВЗРЫВЕ //Научно-практические пути повышения экологической устойчивости и социально-экономическое обеспечение сельскохозяйственного производства. – 2017. – С. 1150-1153.
111. Беккулов Б. Р., Собиров Х. А., Рахманкулов Т. Б. РАЗРАБОТКА И ОБОСНОВАНИЕ ПАРАМЕТРОВ МОБИЛЬНОГО УСТРОЙСТВО ДЛЯ СУШКИ ШАЛА //Энергоэффективные и ресурсосберегающие технологии и системы. – 2020. – С. 429-438.
112. Эрматов К. М. Обоснование параметров приспособления к хлопковой сеялке для укладки фоторазрушаемой пленки на посевах хлопчатника. Автореф. канд. дисс. Янгиюль, 1990. – 1990.
113. Махсудов П. М., Акбаров Ш. Б., Уришев У. Г. Факторы, влияющие на снижение полноты сбора хлопка при машинной уборке //Высшая школа. – 2016. – Т. 2. – №. 24. – С. 60-62.
114. Шермухамедов А. А., Байназаров Х. Р. УСОВЕРШЕНСТВОВАНИЯ КОНСТРУКЦИИ АВТОТРАКТОРНЫХ САМОСВАЛЬНЫХ ПРИЦЕПОВ //The 4th International scientific and practical conference “Science and education: problems, prospects and innovations”(December 29-31, 2020) CPN Publishing Group, Kyoto, Japan. 2020. 808 p. – 2020. – С. 760.
115. Рахимов А. Ю., Рахимов А. А., Қодиров З. ПИЛЛАНИ ПИШИБ ЕТИЛГАНЛИК ДАРАЖАСИНИ СИФАТ КЎРСАТКИЧЛАРИГА ТАЪСИРИ //Academic research in educational sciences. – 2021. – Т. 2. – №. 11. – С. 33-41.
116. Қодиров З. А., Парпиев С. Ф. ПИЛЛАГА ДАСТЛАБКИ ИШЛОВ БЕРИШ ТЕХНОЛОГИЯЛАРИНИНГ ПИЛЛА СИФАТИГА ТАЪСИРИ //Academicresearchineducationalsciences. – 2022. – Т. 3. – №. 2. – С. 637-645.
117. Мамажонов М., Шакиров Б. М., Шакиров Б. Б. АВАНКАМЕРА ВА СУВ КАБУЛ КИЛИШ БУЛИНМАЛАРИНИНГ ГИДРАВЛИК КАРШИЛИКЛАРИ //Irrigatsiya va Melioratsiya. – 2018. – №. 1. – С. 44-46.
118. Эрматов К. М. Вращающий момент бобины с пленкой //Высшая школа. – 2017. – №. 1. – С. 117-118.
119. Эрматов К. М., Шакиров Б. Б. ИЗУЧЕНИЕ ТЕХНОЛОГИЧЕСКОГО ПРОЦЕССА РАССТИЛА ПЛЕНКИ //OF INTERNATIONAL SCIENTIFIC-PRACTICAL CONFERENCE "AUEZOV READINGS-20:DEDICATED TO THE 125th ANNIVERSARY OF M. O. AUEZOV THE HERITAGE OF MUKHTAR AUEZOV – THE TREASURE OF THE NATION". Шымкент. – 2022. – С. 288-291.
120. Қодиров З. А., Парпиев С. Ф. ПИЛЛАГА ДАСТЛАБКИ ИШЛОВ БЕРИШ ТЕХНОЛОГИЯЛАРИНИНГ ПИЛЛА СИФАТИГА ТАЪСИРИ.
121. Рахимов А. А., Парпиев С. Ф. ВЛИЯНИЕ ДЛИТЕЛЬНОСТИ ОТВАРКИ НА КОЛИЧЕСТВО УВАРА ПРИ ПЕРВИЧНОЙ ОБРАБОТКЕ ВОЛОКНИСТЫХ ОТХОДОВ НАТУРАЛЬНОГО ШЕЛКА

INFLUENCE OF BREADING DURATION ON THE QUANTITY OF FUVARDURING PRIMARY PROCESSING OF FIBROUS WASTE OF //ПРОБЛЕМЫ ТЕКСТИЛЬНОЙ ОТРАСЛИ И ПУТИ ИХ РЕШЕНИЯ: Сборник научных трудов Всероссийского круглого стола с международным участием (22 декабря 2020 г.). – М.: РГУ им. АН Косыгина, 2021. – 271 с. – 2021. – С. 184.

122. Rano Y., Asadillo U., Go'Zaloy M. HEAT-CONDUCTING PROPERTIES OF POLYMERIC MATERIALS //Universum: технические науки. – 2021. – №. 2-4 (83). – С. 29-31.

123. Каюмов У. А., Хаджиева С. С. НЕКОТОРЫЕ РЕКОМЕНДАЦИИ ПО ПРИМЕНЕНИЮ ПОРОШКОВЫХ СПЛАВОВ ПРИ ВОССТАНОВЛЕНИИ ДЕТАЛЕЙ СЕЛЬСКОХОЗЯЙСТВЕННОЙ ТЕХНИКИ СПОСОБАМИ ПЛАЗМЕННОЙ НАПЛАВКИ И НАПЫЛЕНИЯ //The 4th International scientific and practical conference "Science and education: problems, prospects and innovations"(December 29-31, 2020) CPN Publishing Group, Kyoto, Japan. 2020. 808 p. – 2020. – С. 330.

124. Джалилов М. Л., Хаджиева С. С., Иброхимова М. М. Общий анализ уравнения поперечного колебания двухслойной однородной вязкоупругой пластинки //International Journal of Student Research. – 2019. – №. 3. – С. 111-117.

125. **Қодиров З., Зулфиқоров Д. ПИЛЛАНИ БУҒЛАШ ТЕХНОЛОГИК ЖАРАЁНИНИНГ ХОМ ИПАК СИФАТИГА ТАЪСИРИ //Eurasian Journal of Academic Research. – 2023. – Т. 3. – №. 1 Part 3. – С. 159-165.**

126. Мамажонов З. А., ўғли Зулфиқоров Д. Р. САБЗИНИНГ КЕСКИЧ ТИФИГА ТАЪСИР КУЧИНИ АНИҚЛАШ //INTERNATIONAL CONFERENCES. – 2023. – Т. 1. – №. 2. – С. 476-481.

127. Mamajonov Z. A. et al. RESPUBLIKAMIZDA QO 'LLANILAYOTGAN EKSKAVATORLARNING CHO 'MICH TISHLARINI QAYTA TIKLASH USULLARINI TAKOMILLASHTIRISHNING TAHLILI //INTERNATIONAL CONFERENCES. – 2023. – Т. 1. – №. 2. – С.

128. Беккулов Б. Р., Ибрагимжанов Б. С., Рахмонкулов Т. Б. ПЕРЕДВИЖНОЕ СУЩИЛЬНОЕ УСТРОЙСТВО ДЛЯ ЗЕРНИСТЫХ СЕЛЬСКОХОЗЯЙСТВЕННЫХ ПРОДУКТОВ //Современные тенденции развития аграрного комплекса. – 2016. – С. 1282-1284.

129. Rahmonkulovich B. B., Abdulhaevich R. A., Sadikovna H. S. The energy-efficient mobile device for grain drying //European science review. – 2017. – №. 11-12. – С. 128-132.

130. Bekkulov B. R. ABOUT VALUE DRYING OF THE DEVICE IN PROCESSING OF GRAINS //Irrigation and Melioration. – 2018. – Т. 2018. – №. 1. – С. 60-63.

131. Bekkulov, B. R. "ABOUT VALUE DRYING OF THE DEVICE IN PROCESSING OF GRAINS." Irrigation and Melioration 2018.1 (2018): 60-63.

132. ЧИРЦОВ С. П. и др. Пленкоукладчик. – 1992.

133. Kobuljon Mo'minovich , E. ., Bobur Mirzo, S. ., & Oltinoy, Q. . (2023). BOMBA KALORIMETR ISHLASH JARAYONI VA XISOBI. *Scientific Impulse*, 1(5), 1800–1804. Retrieved from <http://nauchniyimpuls.ru/index.php/ni/article/view/3320>.